

INSTALLATION INSTRUCTIONS: i2.5 - INGROUND UPLIGHT

T6 HID Fixture Shown

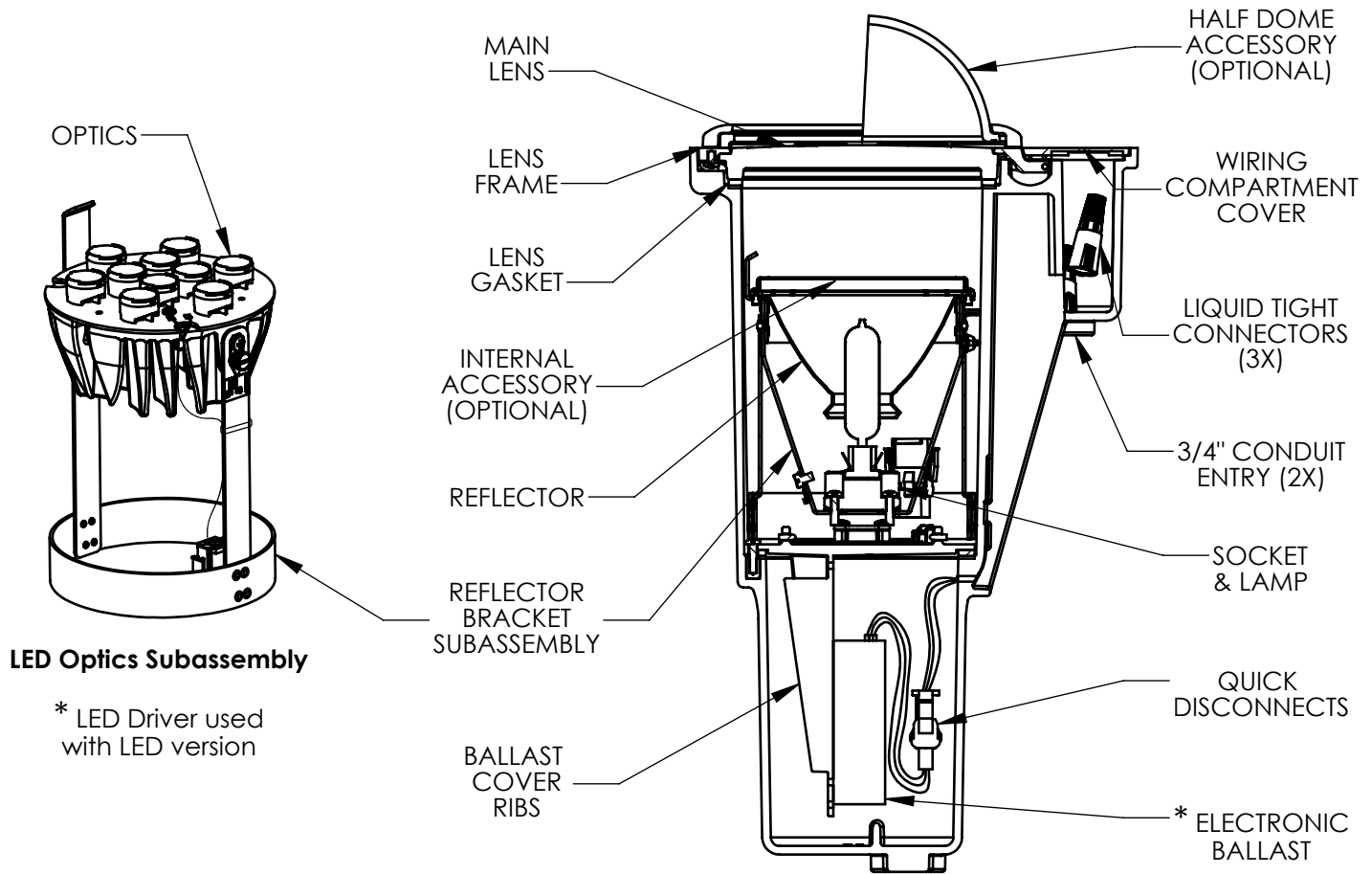

Note: Fixture style, accessories, optics, and ballast type will vary with fixture options.

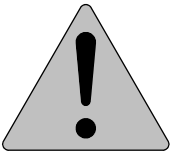

This fixture is intended for installation in accordance with the National Electrical Code and local code specifications. Failure to adhere to these codes and instructions may result in serious injury and/or damage to the ballast and void the warranty. These instructions do not purport to cover all details or variations in equipment, nor to provide for every possible contingency related to installation, operation, maintenance, or mounting situation. Should specific problems occur that are not addressed by these instructions, contact your distributor or Sales Representative for assistance. Retain these instructions for future reference.



CAUTION:

1. **WARNING:** TURN THE POWER OFF BEFORE INSTALLING OR PERFORMING ANY MAINTENANCE ON THIS FIXTURE. Failure to do so may result in severe injury or death.
2. The housing should not be installed in insulating materials such as bark, vermiculite, etc. for the full depth of the housing. Surface use of these materials around BUT NOT ON TOP of the fixture is acceptable.
3. **IMPORTANT:** To prevent overheating, regularly check lens and keep it clean and free of debris such as dirt, sand, leaves, mulch, etc. **Failure to do so will void warranty and could cause a fire.**
4. Conduit entry ways should be properly sealed around threads. Unused conduit entry ways should be properly plugged and sealed. **Failure to do so will void warranty.**
5. The fixture should not be installed in low lying areas or where water may accumulate and stand for long periods of time.
6. Soil should be mounded up around the fixture to promote drainage.
7. Do not install fixture within 10 feet (3 meters) of a pool, spa or fountain.

INSTALLATION

STEP 1: Excavate soil for fixture, or fixture with CPS25 (see CPS25 Installation Instructions for more details), as well as conduit. Contour the hole to the shape of the housing, allowing 3" minimum around and under the housing for placement of sand or granular material. If the installation is in concrete, the fixture must be placed on a 3" minimum bed of gravel with soil below.

Soil or cement removed for fixture and conduits.

NO CPS25

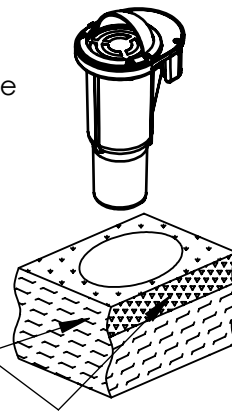

CPS25

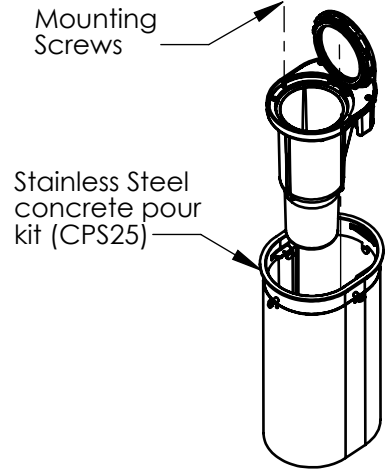

STEP 2: Connect conduit using thread sealant.

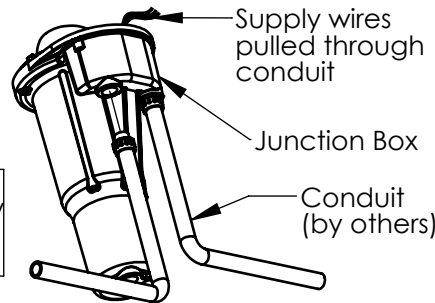

STEP 3: Remove junction box cover. Pull wires through conduit into junction box. The contractor must pull a ground wire or make a ground connection to a metal conduit system.

Unused conduit entry ways should be properly plugged and sealed at junction box.

Failure to properly seal conduit may allow water into junction box and will void the warranty.

STEP 4: Backfill around housing with dirt, cement or decorative stone or backfill around CPS25 with concrete as required for finishing the particular installation. Housing should be surrounded by a 3" minimum layer of sand or gravel to ensure proper drainage. DO NOT back fill with bark or vermiculite.

STEP 5: Connect supply leads to the fixture wiring using the supplied liquid tight wire nuts. Re-attach the junction box cover until screws bottom out.

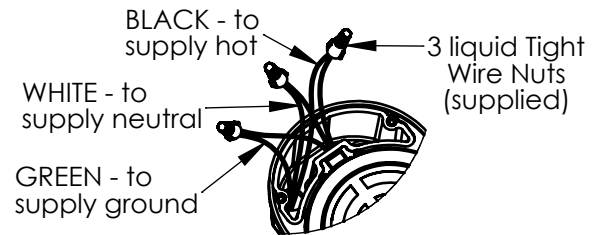

STEP 6: Open main lens assembly by unscrewing two screws. Discard protective packing material from housing. Remove optics subassembly. Install appropriate lamp per the lamp label (not applicable for LED version) - avoid touching glass bulb or optics as much as possible.

STEP 7: To aim optics subassembly, loosen thumbscrew, aim in direction desired (reference aiming label), tighten thumbscrew. Ensure wires are inside the bottom band to prevent pinching wires. Set optics subassembly back into housing and press down until it locks in place.

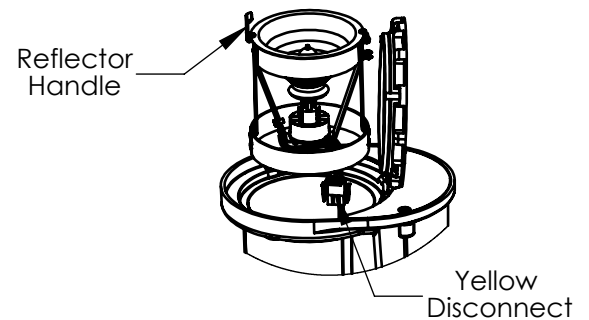

STEP 8: **NOTE: To help decrease moisture**, energize fixture for 20 minutes prior to sealing the main lens assembly. Ensure gasket seating surfaces are clean and free of debris before sealing. Close main lens assembly and seal by tightening two screws until they bottom out.

Tighten two screws to seal.

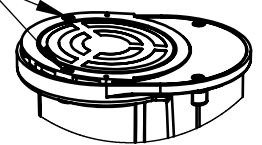

RELAMPING

Loosen screws and open main lens assembly. Inspect gasket - if damaged, then replace lens and gasket assembly. Remove any internal accessory (if applicable). Replace lamp with a new one of identical electrical characteristics. [NOTE: For metal halide T6 (G12 base) and T4 (G8.5) lamps, Hadco recommends using only Philips MasterColor lamps. If using a lamp from another manufacturer, ensure it is electrically compatible with supplied ballast]. For LED version, consult the factory for a replacement light engine. Replace internal accessory (if applicable). Re-seal the fixture per STEP 8 above - ensure gasket sealing surfaces are clean and free of debris.