

PHILIPS

100 Craftway, P.O. Box 128
Littlestown, Pennsylvania 17340-0128

INSTALLATION INSTRUCTIONS: 12V TRIANGULAR WALL LIGHT

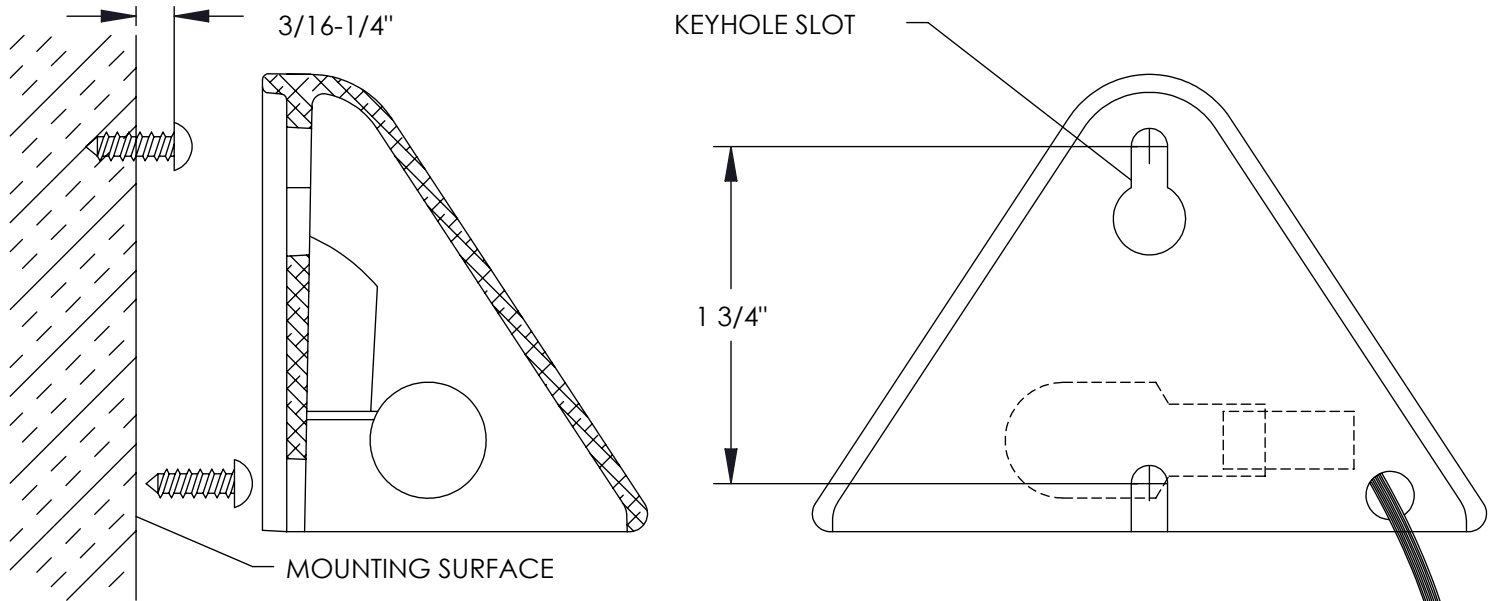

This fixture is rated for a 12W Max. 12V T3-1/4 or T5 Xenon or Incandescent wedge base lamp. Lower wattages may also be used. Included with the fixture is a T3-1/4 10W 12V Xenon wedge base lamp.



This fixture is intended for installation in accordance with the National Electrical Code and local code specifications. Failure to adhere to these codes and instructions may result in serious injury and/or damage to the ballast and void the warranty. These instructions do not purport to cover all details or variations in equipment, nor to provide for every possible contingency related to installation, operation, maintenance, or mounting situation. Should specific problems occur that are not addressed by these instructions, contact your Sales Representative or distributor for assistance. Retain these instructions for future reference.



INSTRUCTIONS PERTAINING TO A RISK OF FIRE OR INJURY TO PERSONS-IMPORTANT SAFETY INSTRUCTIONS
Lighted lamp is HOT! WARNING- To reduce the risk of FIRE OR INJURY TO PERSONS: Turn off/unplug and allow to cool before replacing lamp. Lamp gets HOT quickly! Contact only switch/plug when turning on. Do not touch hot lens, guard, or enclosure (see diagram/picture). Keep lamp away from materials that may burn. Do not touch the lamp at any time. Use a soft cloth. Oil from skin may damage lamp. Do not operate the luminaire fitting with a missing or damaged shield. **SAVE THESE INSTRUCTIONS.**
Xenon lamps do not require additional shielding.

FOR USE ONLY WITH LOW VOLTAGE LANDSCAPE LIGHTING POWER UNITS THAT ARE RATED
MAXIMUM 25 AMPS, 15 VOLTS PER CIRCUIT.

INSTALLATION INSTRUCTIONS

1. Make sure power is turned OFF before installing or servicing this fixture.
2. Drill pilot holes for #8 screws (1-3/4" apart) using above full size figure as a template.
3. Screw #8 screws in to pilot holes leaving approximately 3/16" to 1/4" gap between the head of the screw and the mounting surface. (Note: Screws 1/2" to 5/8" in length are recommended.)
4. Place head of top screw through keyhole of top slot, put fixture against mounting surface and slide fixture down over threads of both screws to hang it.
5. Tighten bottom screw to secure fixture to the mounting surface.
6. Wire fixture following instructions below for low voltage connector.
7. Turn power ON.

LOW VOLTAGE CABLE CONNECTOR INSTRUCTIONS

Low voltage cable connector to be used with 10 or 12 gauge supply cable and 18 gauge fixture cable. Philips recommends using SPT-3 water resistant (marked "WA", "W" or similar marking) supply cable such as our SCW500-10/BSCW500-10 or our SCW100-12/BSCW100-12. Philips also recommends ordering the entire system, which includes the power console (maximum 25 Amps, 15 Volts per circuit), fixture(s) (low voltage cable connector included) and supply cable to ensure proper installation and operation.

When using our supply cable, it can be laid on top of the ground, placed under "ground cover" (that is, shallow burial less than 6 inches or 15.2 cm deep), or directly buried in accordance with the NEC. If not using our cable, per UL 1838-Standard for Low Voltage Landscape Lighting Systems, the secondary cable must be SPT-3 or suitable for wet locations, sunlight resistant and direct burial per UL 493 and sized per UL 1838, and it must be buried less than 6 inches (15.2 cm). Philips recommends a minimum depth of 4 inches when burying in the lawn to prevent damage from aerators or other lawn plugging equipment.

The 18 gauge fixture cable (provided with fixture) must be protected by routing in close proximity to the fixture or secured to a building structure such as a house or deck. The fixture cable must be cut off so that it is connected to the low voltage cable connector within 6 inches (15.2 cm) of the fixture or the building structure. When making an underground connection to the 10 or 12 gauge supply cable (not provided), the fixture cable must not be buried more than 6 inches (15.2 cm).

WARNING-Mount the luminaire in or on non-combustible mounting surfaces only.

WARNING-Risk of Electric Shock. Install all luminaires 10 feet (3.05m) or more from a pool, spa, or fountain.

1. Connect the supply cable to the terminals on the power console (transformer) and turn ON.
2. Disassemble the connector by removing the Phillips head screw.
3. Inspect the connector to ensure the prongs are straight. If the prongs are bent, straighten with pliers.
4. Insert the end of the fixture cable into the square opening in the connector body. Bend wire over so that wire is laying in the recess marked '18 GA'. This will help hold the wire in place while performing steps 5 and 6. Only 2-wire cable is to be used and the common (smooth) wire and hot (ribbed) wires must be oriented as shown.
5. Press the supply cable into the recess marked '10,12/2 GA' on the connector body. Again the common (smooth) wires and the hot (ribbed) wires must be oriented as shown.
6. Press the connector cover onto the connector body, making sure the screw holes line up with each other.
7. Assemble the connector by tightening the Phillips head screw. NOTE: Make sure the metal prongs in the connector pierce all 4 wires; the fixture will light as the prongs pierce the wires.

